

Electric Brakes

MTB Series – Modular Tension Brakes

One of the keys to the Warner Electric tensioning system is the Electro Disc tension brake. Electro Disc brake systems are capable of continuous slip from full roll to core diameter while providing outstandingly consistent and accurate control of unwind tension throughout the process. Electro Disc brakes operate smoothly and quietly. They respond instantly for emergency stops. Wear life is remarkable. Electronic control systems are easily interfaced with Warner Electric controls. Selection of the right brake for virtually any web processing application, from film to boxboard, is made possible through a building-block modular design.

Simple Maintenance

Rugged design eliminates most moving parts. No diaphragms to break down. Asbestos-free brake pads are quickly and easily replaced. Brake wear does not affect torque as with some other types of brakes.

Easy Installation

Electro Disc tension brakes fit within tight space restrictions. Bushings adapt to most standard and metric shafts. Electrical installation replaces complex pneumatic plumbing, valves and compressors.

Long Life, High Heat Dissipation

A replaceable face armature disc provides extremely long life and maximum heat dissipation. Standard armature discs can be mounted singly or in tandem as shown here to increase the heat dissipation and torque capability.

Accurate, Consistent Control

The responsiveness of electric brakes coupled with specially designed controls provides accurate tensioning from beginning to end of roll, even during emergency stops and flying splices.

Brake Modularity

With one to sixteen magnets and single or double armature discs, Electro Disc tension brakes offer torque control and continuous slip capacity to meet a broad spectrum of requirements for virtually any web processing application.

Four armature sizes

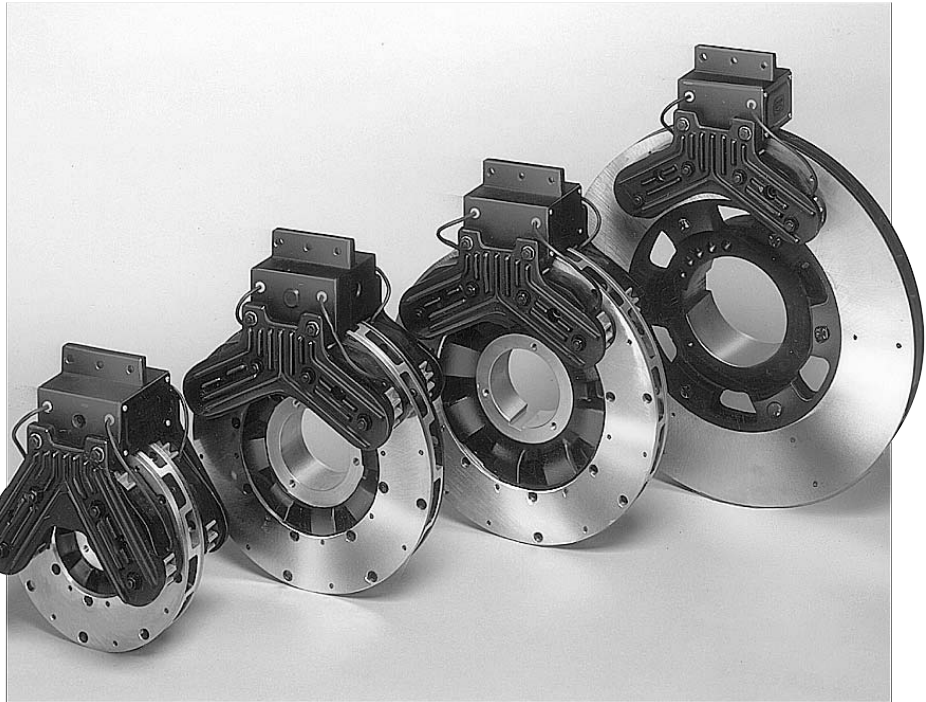

Patented Design

The patented Electro Disc design is a proven concept, featuring a simple, yet powerful tension brake ... easy-to-control, smooth, quiet and accurate. The speed of response and controllability, especially near zero tension, far exceeds that of other braking technologies.

Simple. Powerful. Controllable.

The electromagnetic principle, as applied to the Electro Disc tension brake, results in a brake design that features outstanding control from zero torque to the maximum limits of the brake. Complex moving parts are eliminated.

Smooth Operation with Minimal Maintenance

The friction pads are made of a unique composite of asbestos-free friction materials specially designed to produce smooth, powerful, yet quiet engagement between the magnet and armature discs. Since the replaceable friction pads and armature disc are the only parts which receive regular wear, the electromagnets can be reused indefinitely. An indicator notch on the friction pad, as well as an optional electric wear indicator, makes routine checking for remaining wear life quick and easy.

MTB-II ... the second generation

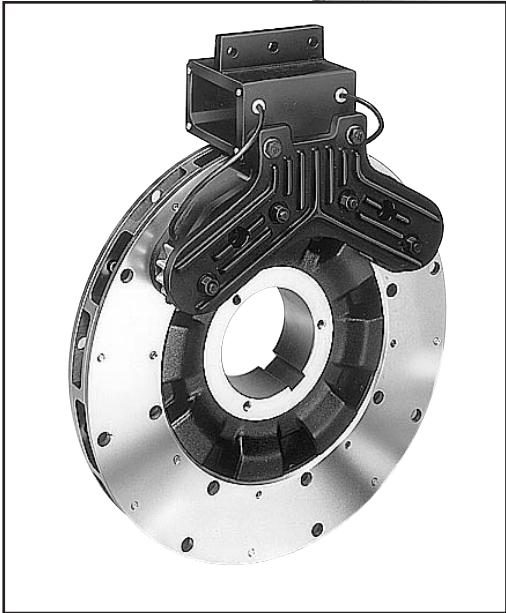
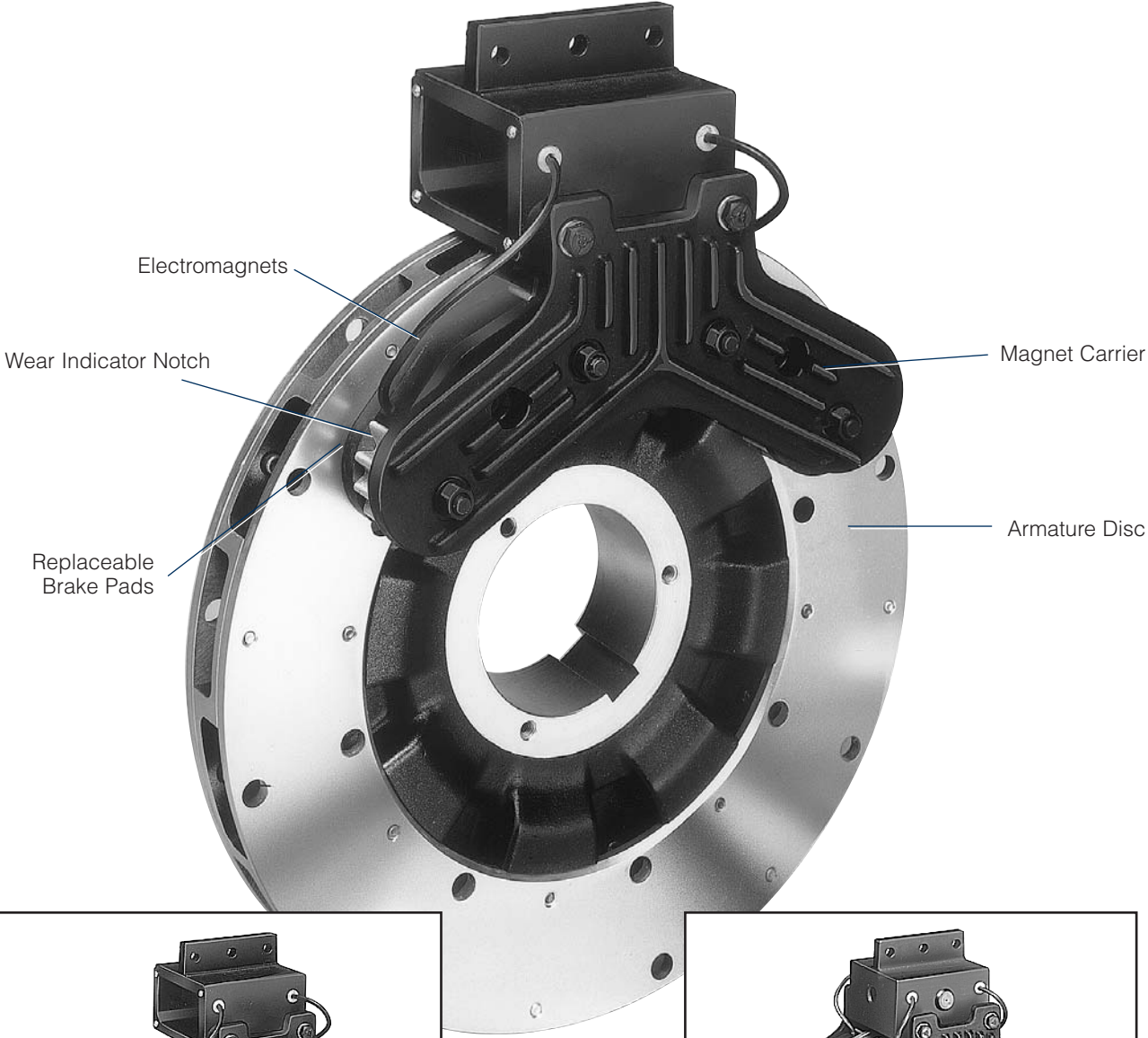

Single disc, 2 magnets

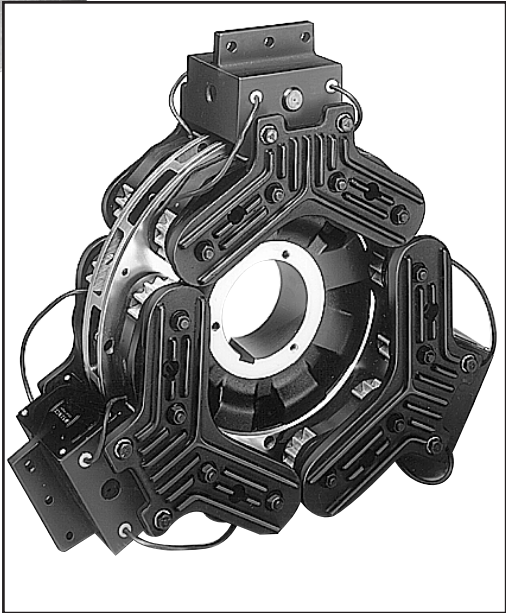

Dual disc, 12 magnets

Electric Brakes

MTB Series – Modular Tension Brakes

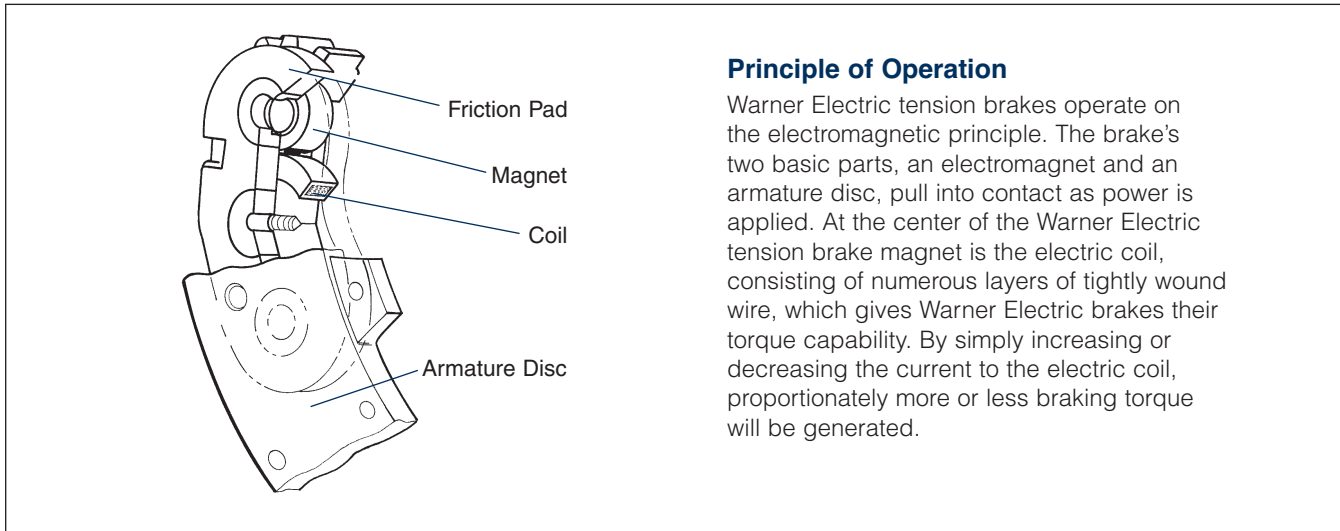

MTB-II...The Second Generation

The ED magnet has been redesigned following years of engineering tests and evaluation. The result is a unique, patent pending design providing more than double the life of the previous Electro Disc brakes ... without any loss in smoothness or controllability.



New armature design

New aluminum armature carriers for 10", 13" and 15" systems provide inertial reduction up to 40%, allowing improved tension control as high speed machines accelerate to core. The radial blower design improves air flow and cooling. Systems run cooler and last longer.



New friction system

The friction system features three important benefits:

- A new, long wearing friction pad material.
- A new, improved balance between the wear rate of the magnetic poles and the friction material.
- A replaceable face friction pad for fast, easy maintenance.

New pole geometry

The geometry of the magnetic poles has been redesigned (Patent Pending) to minimize the "leading edge wear" common to all pin mounted friction brakes. Magnet mounting holes do not extend through the face for freer, axial movement.



New electronic wear indicator option

An optional, electronic wear indicator is imbedded into the magnets to aid in planning maintenance requirements. An indicator on the Warner Electric control illuminates at the point where 15% of brake life still remains.

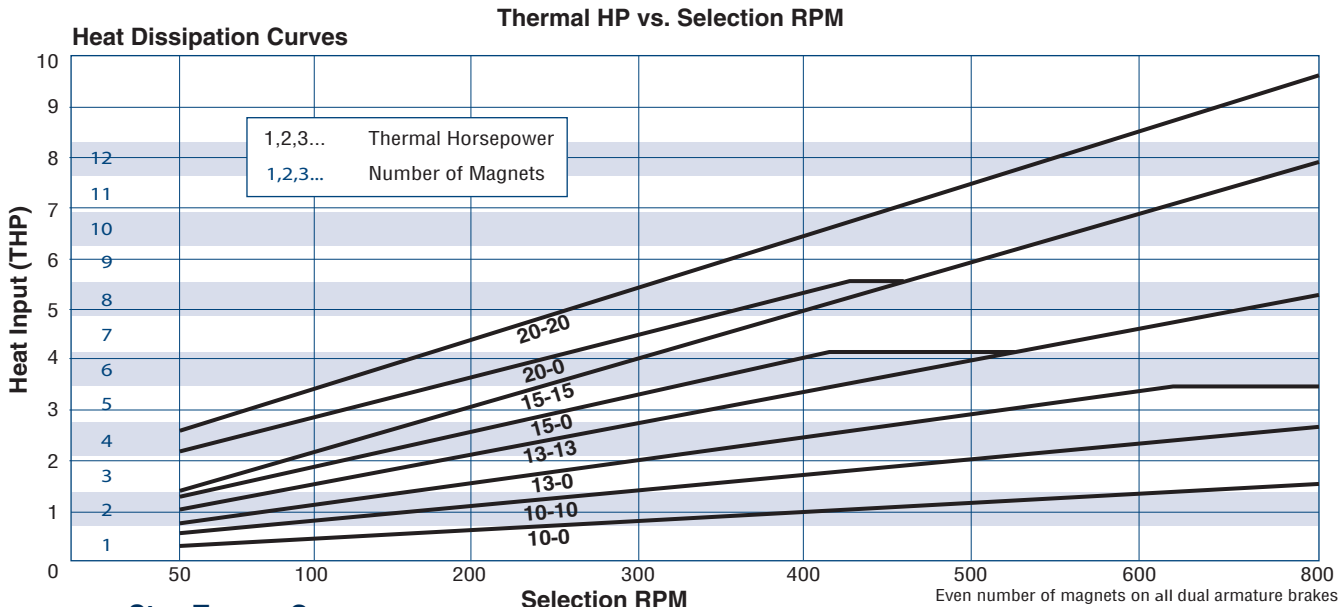

Emergency Stop Torque Curves

Note: The following curves are for emergency stop torques. For normal running dynamic torque, multiply the emergency stop torque value by .54.

Electro Disc – 10"*

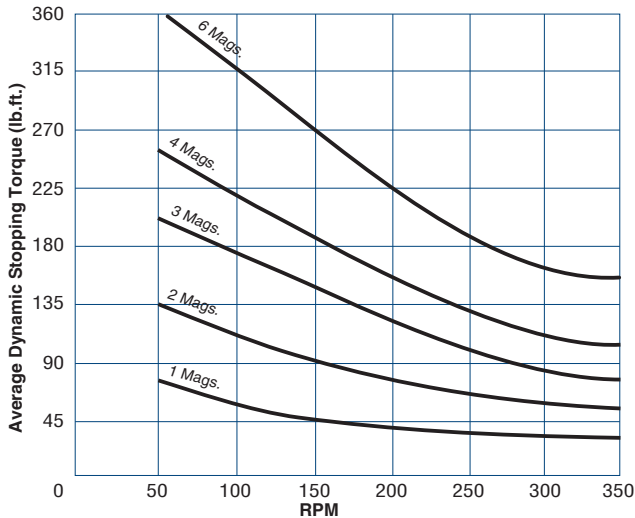

Electro Disc – 13"*

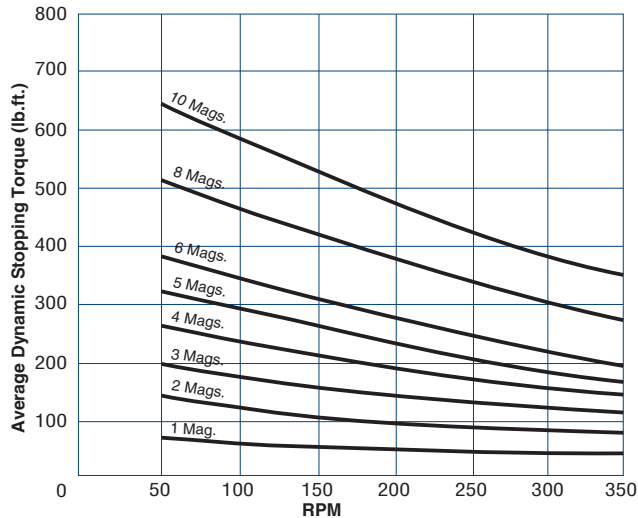

Electro Disc – 15"*

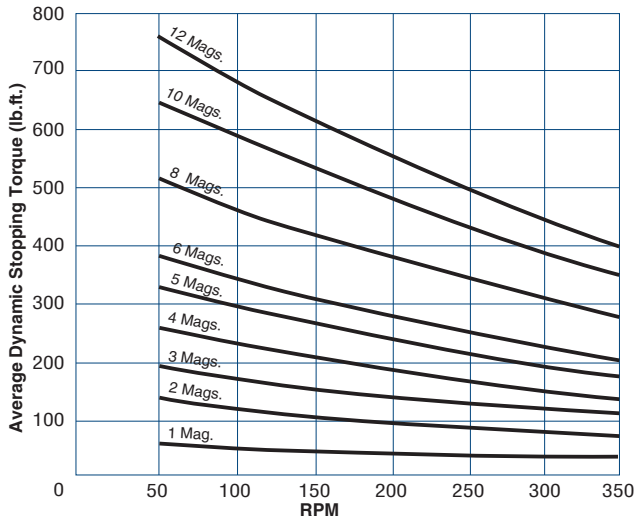

Electro Disc – 20"*

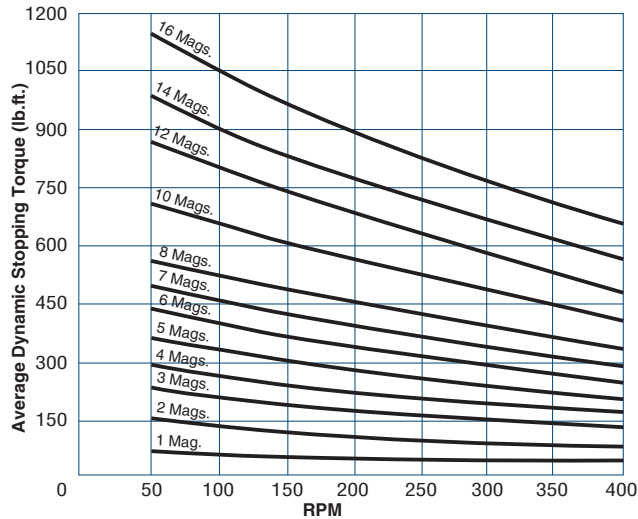

* MTB II Dynamic Torques at 500 mA per magnet, available from TCS series controls during emergency stop.

Electric Brakes

MTB Series – Modular Tension Brakes

Model number designation



Single Disc, 2 Magnets

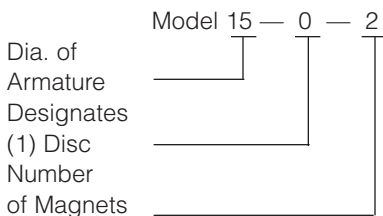

Dual Discs, 4 Magnets

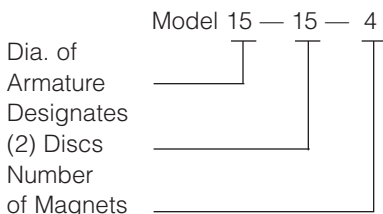

Dual Discs, 12 Magnets

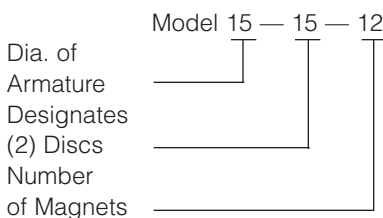

Specifications

Model	No. of Discs	No. of Magnets	Resistance @20°C Ohms ¹	Current Amps	Watts ¹	Max. Allowable Disc Speed RPM
10-0-1	1	1	69.10	0.35	8.33	3600
10-0-2	1	2	34.55	0.69	16.67	3600
10-0-3	1	3	23.03	1.04	25.01	3600
10-10-2	2	2	34.55	0.69	16.67	3600
10-10-4	2	4	17.28	1.39	33.33	3600
10-10-6	2	6	11.52	2.08	50.0	3600
13-0-1	1	1	69.10	0.35	8.33	2500
13-0-2	1	2	34.55	0.69	16.67	2500
13-0-3	1	3	23.03	1.04	25.01	2500
13-0-4	1	4	17.28	1.39	33.33	2500
13-0-5	1	5	13.82	1.74	41.68	2500
13-13-2	2	2	34.55	0.69	16.67	2500
13-13-4	2	4	17.28	1.39	33.33	2500
13-13-6	2	6	11.52	2.08	50.0	2500
13-13-8	2	8	8.64	2.78	66.67	2500
13-13-10	2	10	6.91	3.47	83.36	2500
15-0-1	1	1	69.10	0.35	8.33	2500
15-0-2	1	2	34.55	0.69	16.67	2500
15-0-3	1	3	23.03	1.04	25.01	2500
15-0-4	1	4	17.28	1.39	33.33	2500
15-0-5	1	5	13.82	1.74	41.68	2500
15-0-6	1	6	11.52	2.08	50.0	2500
15-15-2	2	2	34.55	0.69	16.67	2500
15-15-4	2	4	17.28	1.39	33.33	2500
15-15-6	2	6	11.52	2.08	50.0	2500
15-15-8	2	8	8.64	2.78	66.67	2500
15-15-10	2	10	6.91	3.47	83.36	2500
15-15-12	2	12	5.76	4.17	100.0	2500
20-0-1	1	1	69.10	0.35	8.33	1600
20-0-2	1	2	34.55	0.69	16.67	1600
20-0-3	1	3	23.03	1.04	25.01	1600
20-0-4	1	4	17.28	1.39	33.33	1600
20-0-5	1	5	13.82	1.74	41.68	1600
20-0-6	1	6	11.52	2.08	50.0	1600
20-0-7	1	7	9.87	2.43	58.36	1600
20-0-8	1	8	8.64	2.78	66.67	1600
20-20-2	2	2	34.55	0.69	16.67	1600
20-20-4	2	4	17.28	1.39	33.3	1600
20-20-6	2	6	11.52	2.08	50.0	1600
20-20-8	2	8	8.64	2.78	66.67	1600
20-20-10	2	10	6.91	3.47	83.36	1600
20-20-12	2	12	5.76	4.17	100.0	1600
20-20-14	2	14	4.94	4.86	116.60	1600
20-20-16	2	16	4.32	5.56	133.33	1600

Notes: 1. Electrical data based on magnets connected in parallel.

Armature Data

Brake Size	No. of Armatures	Total Brake Inertia (lb.ft. ²)	Armature and Hub* Total Weight (lbs.)
10"	1	0.9	9.4
	2	1.4	14.6
13"	1	2.9	16.6
	2	4.6	25.0
15"	1	4.6	22.3
	2	7.5	32.5
20"	1	20.0	70.0
	2	36.0	105.0

*Armature, hub and bushing rotate

Torque Ratings per Magnet

Brake Size	Dynamic Torque* (lb.ft.)	Drag Torque (lb.ft.)	E-Stop** (lb.ft.)
10"	28.5	.21	62
13"	30	.32	64
15"	33	.37	65
20"	37	.51	70

* Per magnet @ 50 rpm; 270 ma coil current

** Per magnet @ 50 rpm; 500 ma coil current

Modular Design ... tailored to meet your requirements

To select the proper size Electro Disc tension brake, it is important to understand that the brakes are fully modular. This feature enables matching requirements for heat dissipation and emergency stopping torque to the tension brake configuration that optimizes these features.

Selection

The easy-to-use selection charts on page 89 specifies a particular modular combination as listed in the accompanying chart. (See page 90 for selection of basic tension brakes.)

Determining two factors are all that's required.

1. Diameter
Basically heat dissipation capacity is directly proportional to the diameter of the disc.
2. Number of magnets
Torque capacity is proportional to the number of magnets. See page 89 for torque and heat dissipation sizing to meet the specific requirements of your application.

Mounting Configurations

Flexible Mounting

Thrust bearings, side loading, and special supports are a thing of the past!

Universal Mounting Bracket

With addition of a simple "L" shaped bracket (Customer supplied), the universal mount provides a perfectly easy retrofit on older machines.

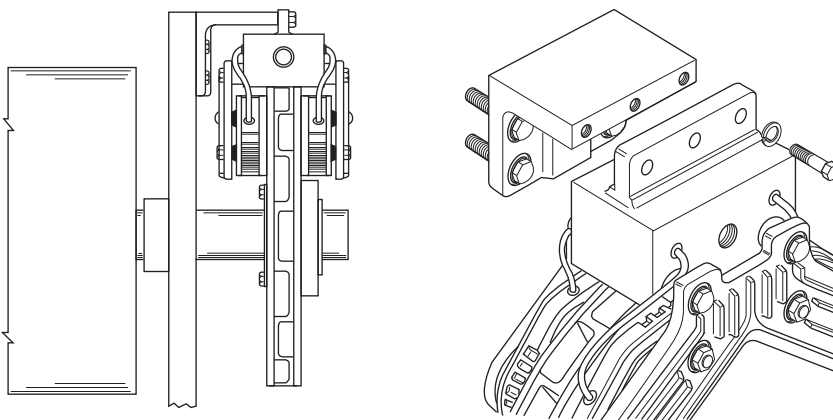

Bulk Head Mounting Bracket

Use of the bulkhead mount reduces the overall diameter to allow mounting in more constricted or enclosed locations.

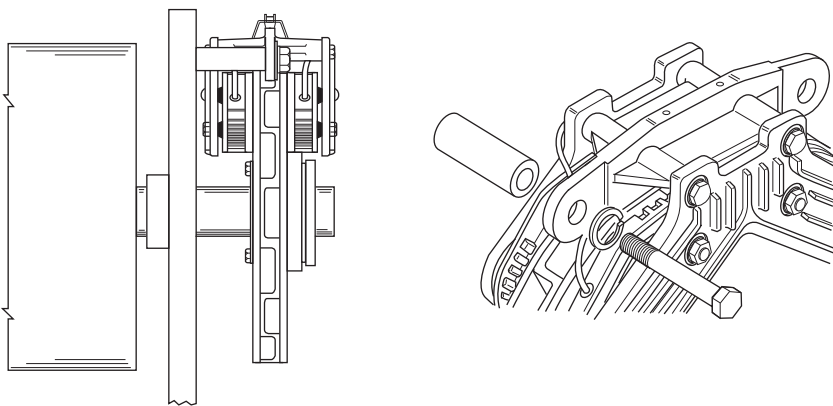

Direct (Free) Mounting

For the Machine Builder or retrofitter, the free mount provides the simplest, least expensive option with low profile and diameter advantages. Mounting directly to the side frame of the machine offers all support necessary for performance requirements.

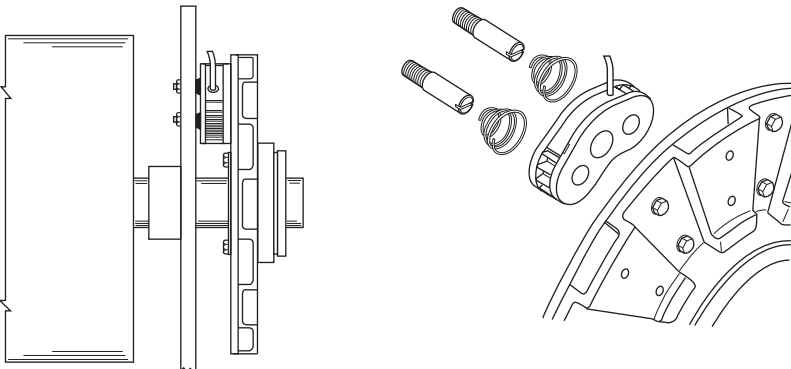

Electric Brakes

MTB Series – Modular Tension Brakes

MTB-II Dimensions

... with Universal Mounting Brackets

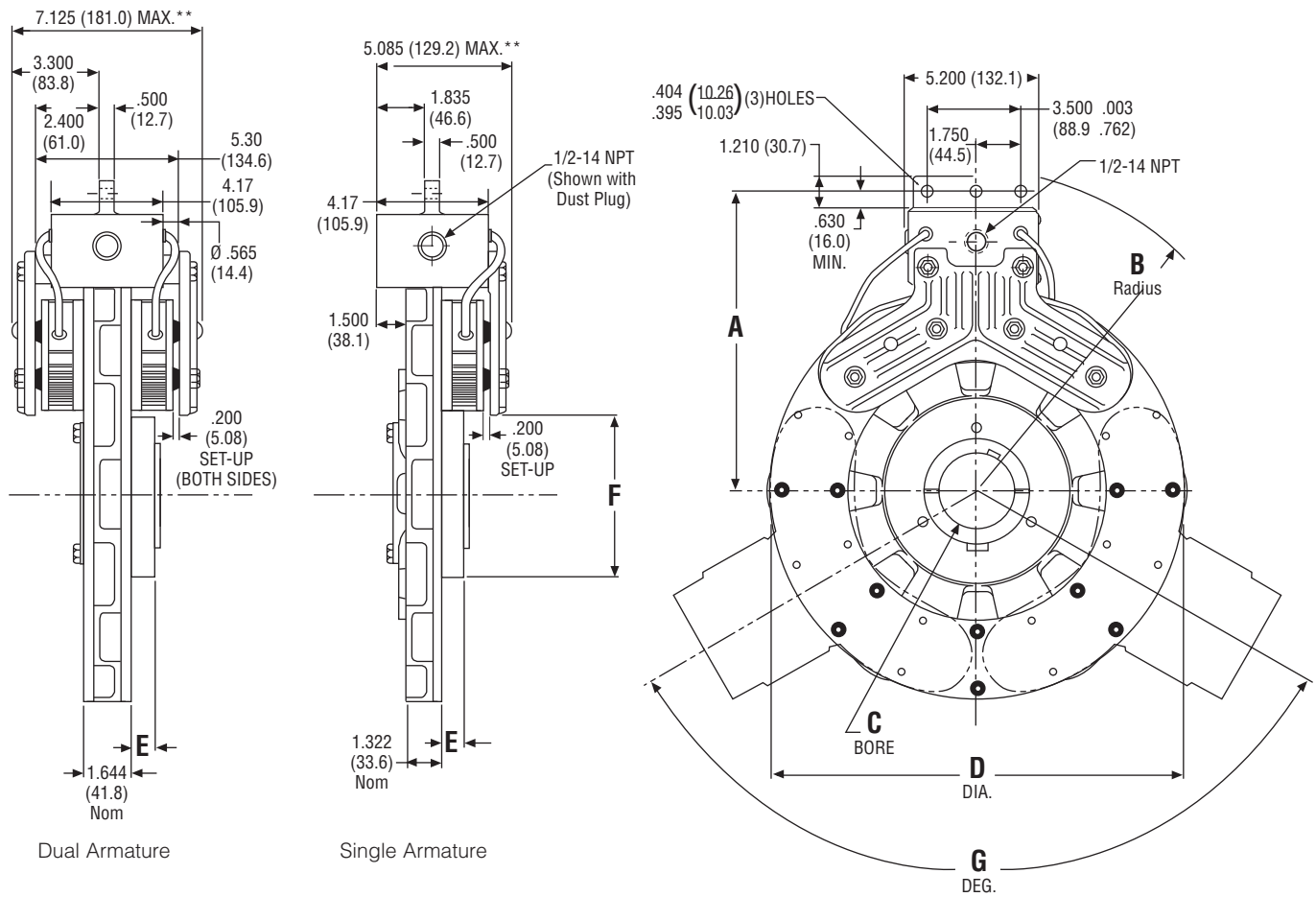

inches (mm)

Armature Size	A	B Max.	C BORE			D Max.	E Max.	F Max.	G Degree
			Stock*	Bushing	Browning				
10"	8.625 ± .020 (219.0 ± 0.5)	9.500 (241.3)	1.750 (44.45)	.500–1.750 (14.0–42.0)	P-1	10.020 (254.5)	.479 (12.2)	3.550 (88.9)	180
13"	10.187 ± .020 (258.7 ± 0.5)	11.000 (279.4)	3.375 (85.73)	1.125–3.750 (28.0–95.0)	R-1	13.520 (343.4)	1.219 (31.0)	5.687 (144.4)	108 & 144
15"	11.125 ± .020 (282.6 ± 0.5)	12.000 (304.8)	3.375 (85.73)	1.125–3.750 (28.0–95.0)	R-1	15.325 (389.3)	1.219 (31.0)	6.875 (174.6)	120
20"	13.470 ± .020 (340.4 ± 0.5)	14.250 (362.0)	— —	2.375–5.500 —	U-0	20.020 (508.5)	2.720 (69.1)	4.380 (111.3)	—

* Stock bore is straight bore for use with Trantorque bushing.

For replacement parts list and exploded view drawing, see page 96.

** Width dimension is the same for single or dual magnet carriers. (Dual magnet carrier shown.)

Consult factory for dimensional information on MTB-I.

Note: All dimensions are nominal unless otherwise noted.

Electric Brakes

MTB Series – Modular Tension Brakes

MTB-II Dimensions

... with Direct Mounting

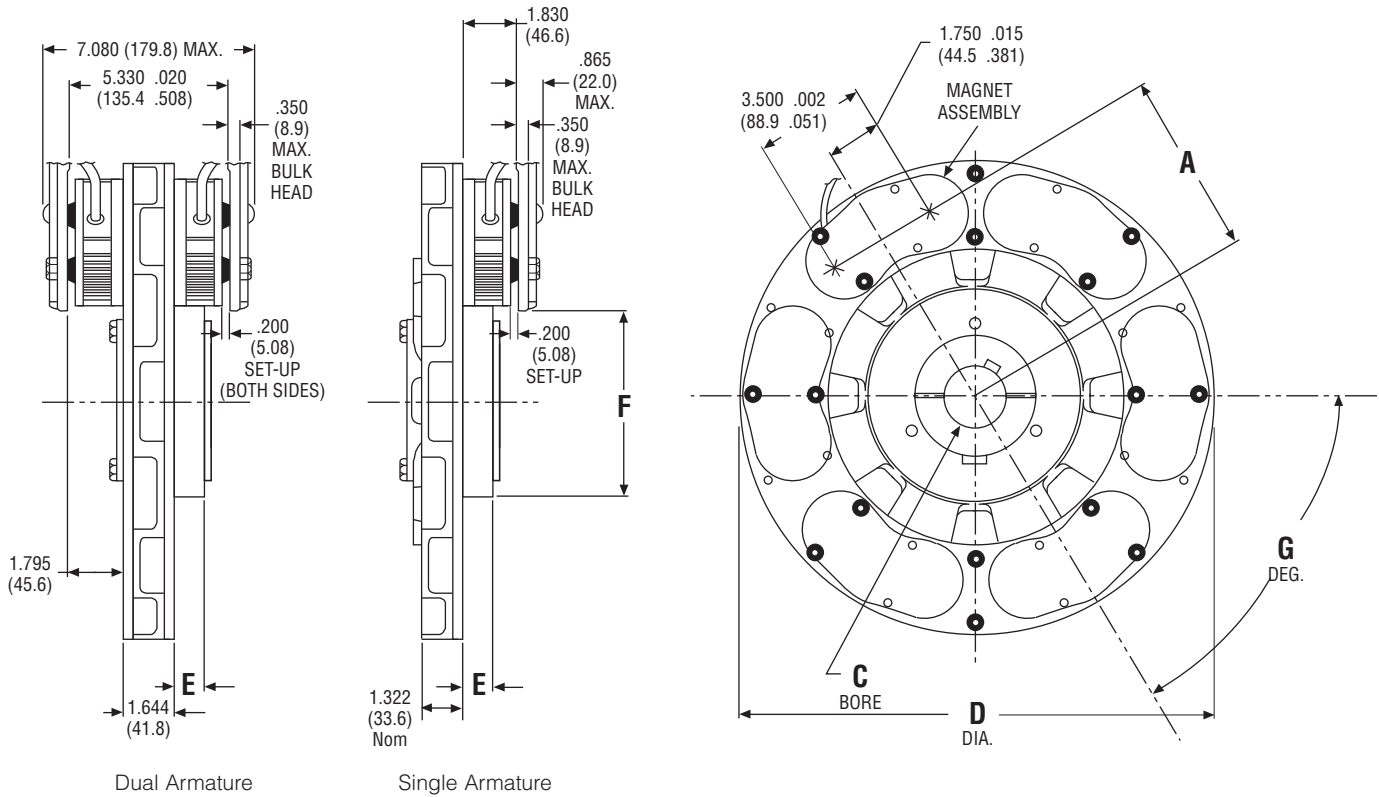

Male Pins

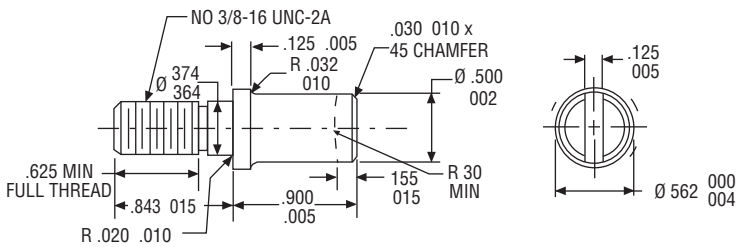

Female Pins

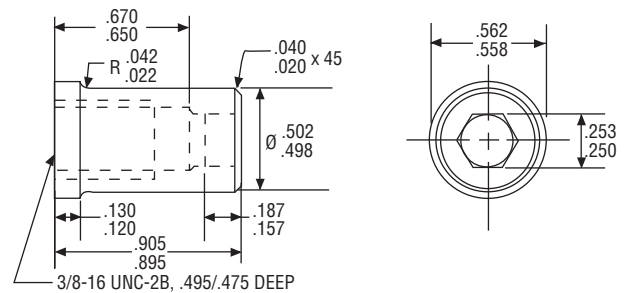

inches (mm)

Armature Size	A	C BORE			D Max.	E Max.	F Max.	G Degree
		Stock*	Bushing	Browning				
10"	3.350 ± .020 (85.1 ± 0.5)	1.750 (44.45)	.500–1.750 (14.0–42.0)	P-1	10.020 (254.5)	.479 (12.2)	3.550 (88.9)	120
13"	5.215 ± .020 (132.5 ± 0.5)	3.375 (85.73)	1.125–3.750 (28.0–95.0)	R-1	13.520 (343.4)	1.219 (31.0)	5.687 (144.4)	72
15"	5.850 ± .020 (148.6 ± 0.5)	3.375 (85.73)	1.125–3.750 (28.0–95.0)	R-1	15.325 (389.3)	1.219 (31.0)	6.875 (174.6)	60
20"	8.125 ± .040 (206.4 ± 1.0)	—	2.375–5.500 —	U-0	20.020 (508.5)	2.720 (69.1)	—	—

* Stock bore is straight bore for use with Trantorque bushing.
For replacement parts list and exploded view drawing, see page 96.
Consult factory for dimensional information on MTB-I.

Note: All dimensions are nominal unless otherwise noted.

Retrofit/Upgrade of MTB to MTB-II

New MTB-II magnets and armature carriers are designed to easily retrofit and upgrade existing MTB applications.

MTB Magnet Weight
3 lb. 4.5 oz. each Magnet

1. **Magnets only** – Existing applications can extend the life of the friction system by installing MTB-II components.

If presently using... MTB MAGNETS

Magnet 5216-631-004

that should go with...

Magnet Carriers

Dual 10" 5216-295-002
13" None
15" & 20" 5216-295-001
Single All 5216-295-003

OR (if Free Mounting)...

Free Mount Pins 5216-101-010
5216-101-008

Upgrade with... MTB-II MAGNETS

Standard Magnet 5216-631-010
or
Magnet with electronic wear indicator 5216-631-009

that should go with...

Dual 10" 5216-295-005
13" 5216-295-006
15" & 20" 5216-295-007
Single All 5216-295-004

OR (if Free Mounting)...

Free Mount Pins 5216-101-029
5216-101-030



Note: a) The same number of magnets should be used unless additional considerations exist (consult factory).
b) MTB-II Free Mount Pins (5216-101-029) may replace the pins in the MTB carriers to convert them into MTB-II carriers.

2. **Aluminum Armature Carriers** – Existing applications may be upgraded to aluminum armature carriers with the benefit of reducing armature inertia. This may be done with or without upgrading the magnets.

If presently using... MTB ARMATURE & HUB

10" Armature 5216-111-001

that should go with...

10" Hub 540-0842

15" Armature 5216-111-003

that should go with...

15" Hub 540-1382

Upgrade with... MTB-II ARMATURE & CARRIER

10" Armature 5216-101-025

that should go with...

Tapered Bore Carrier 295-0021

OR

Straight Bore Carrier 295-0026

15" Armature 5216-101-024

that should go with...

Tapered Bore Carrier 295-0019

OR

Straight Bore Carrier 295-0028



Note: Due to the orientation of the tapered bore in the integral hub of the MTB-II armature carrier, some existing MTB applications may not readily retrofit to the new assembly (consult factory).

Brake Assemblies and Part Numbers

MTB Series – Modular Tension Brakes

MTB II

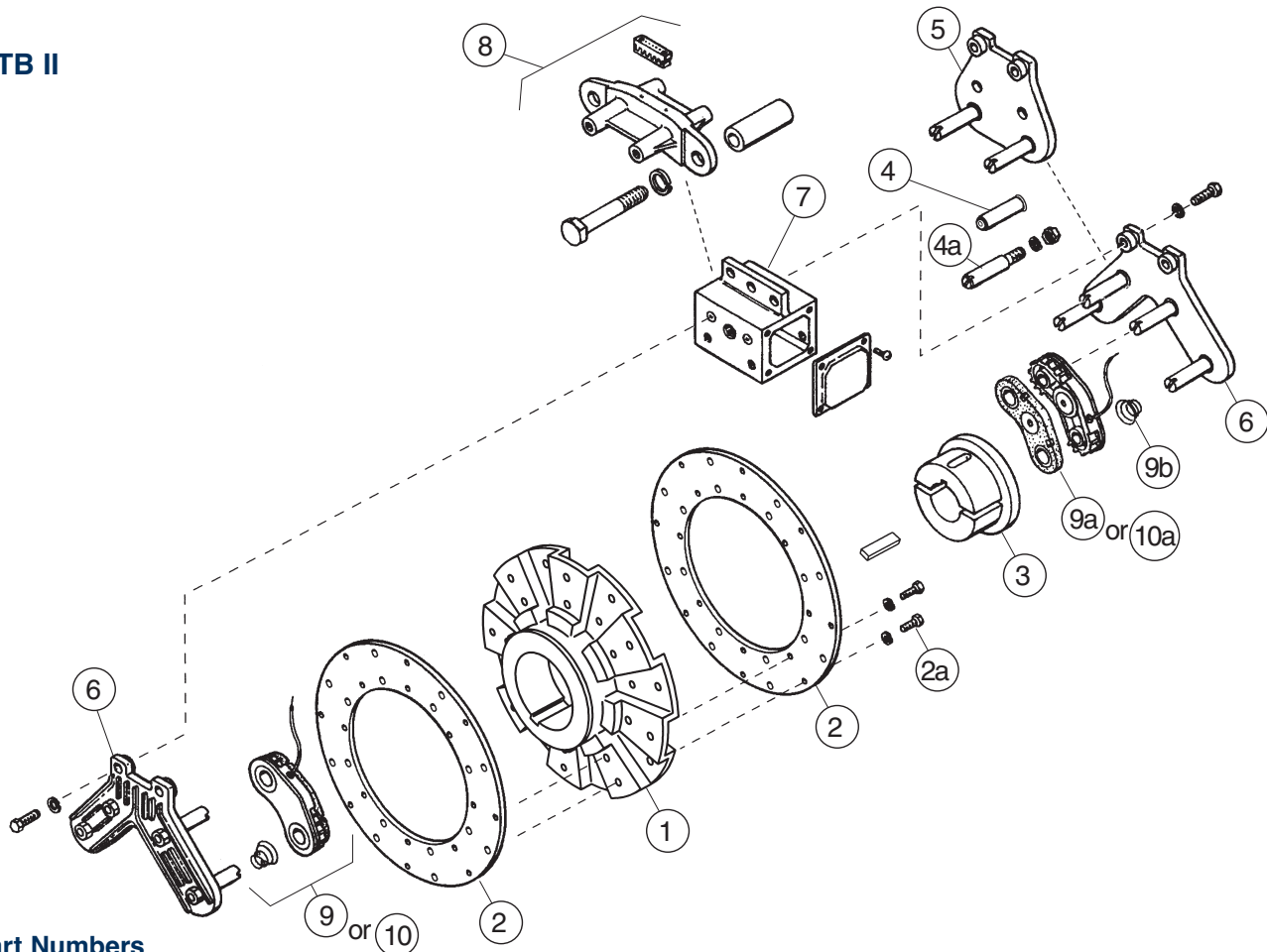

Part Numbers

Item Description	10" Armature	13" Armature	15" Armature	20" Armature*
Armatures				
1 Armature Carrier (Bushing Enters from Flush Side of Carrier as Shown)	295-0021	295-0023	295-0019	—
Armature Carrier Reverse Taper (Bushing Enters from Extended Side of Carrier)	295-0031	295-0030	295-0029	—
Armature Carrier (Straight Bore)	295-0026	295-0027	295-0028	—
2 Armature (Replaceable Face)	5216-101-025	5216-101-026	5216-101-024	—
2a Armature Mounting Accessory (Included with Armature)	5216-101-023	5216-101-023	5216-101-023	—
3 Bushing (Customer Supplied) Taper Bore	Browning P1	Browning R1	Browning R1	—
	Use Trantorque. Consult Warner Electric			—
4 Female Pin Kit (Includes 2 Pins)	5216-101-030	5216-101-030	5216-101-030	5216-101-030
4a Male Pin Kit (Includes 2 Pins with Nuts and Lockwashers)	5216-101-029	5216-101-029	5216-101-029	5216-101-029
Magnet Carriers				
5 Single Magnet Carrier Assembly	5216-295-004	5216-295-004	5216-295-004	5216-295-004
6 Dual Magnet Carrier Assembly	5216-295-005	5216-295-006	5216-295-007	5216-295-007
Carrier Brackets				
7 Universal Mounting Bracket, Series 10-0, 13-0, & 20-0 (2)	5216-101-020	5216-101-020	5216-101-020	5216-101-020
Universal Mounting Bracket, Series 10-10, 13-13, & 20-20 (2)	5216-101-021	5216-101-021	5216-101-021	5216-101-021
8 Bulk Head Mounting Bracket (3)	5216-101-022	5216-101-022	5216-101-022	5216-101-022
Magnets				
9 Magnet Assembly, Standard	5216-631-010	5216-631-010	5216-631-010	5216-631-010
Magnetic Assembly, HICO	5216-631-013	5216-631-013	5216-631-013	5216-631-013
9a Friction Pad, Standard (Replacement Part Only)	5216-101-028	5216-101-028	5216-101-028	5216-101-028
Friction Pad, HICO (4)	5216-101-031	5216-101-031	5216-101-031	5216-101-031
9b Preload Spring (1) (Included with Magnets)	808-0008	808-0008	808-0008	808-0008
10 Magnet Assembly with Wear Indicator	5216-631-009	5216-631-009	5216-631-009	5216-631-009
10a Friction Pad with Wear Indicator (Replacement Part Only)	5216-101-027	5216-101-027	5216-101-027	5216-101-027

(1) Two of each required for each brake magnet.

(2) Includes magnet carrier (4 & 5) mounting hardware.

(3) Includes magnet mounting hardware, bracket mounting bolts and spacers.

(4) HICO friction pads can be identified by orange paint mark near wear notch.

* 20" armature components – see page 97.

Browning is a registered trademark of Emerson Electric Co.

Trantorque is a registered trademark of Trantorque Corporation.

Brake Assemblies and Part Numbers

MTB Series – Modular Tension Brakes

MTB

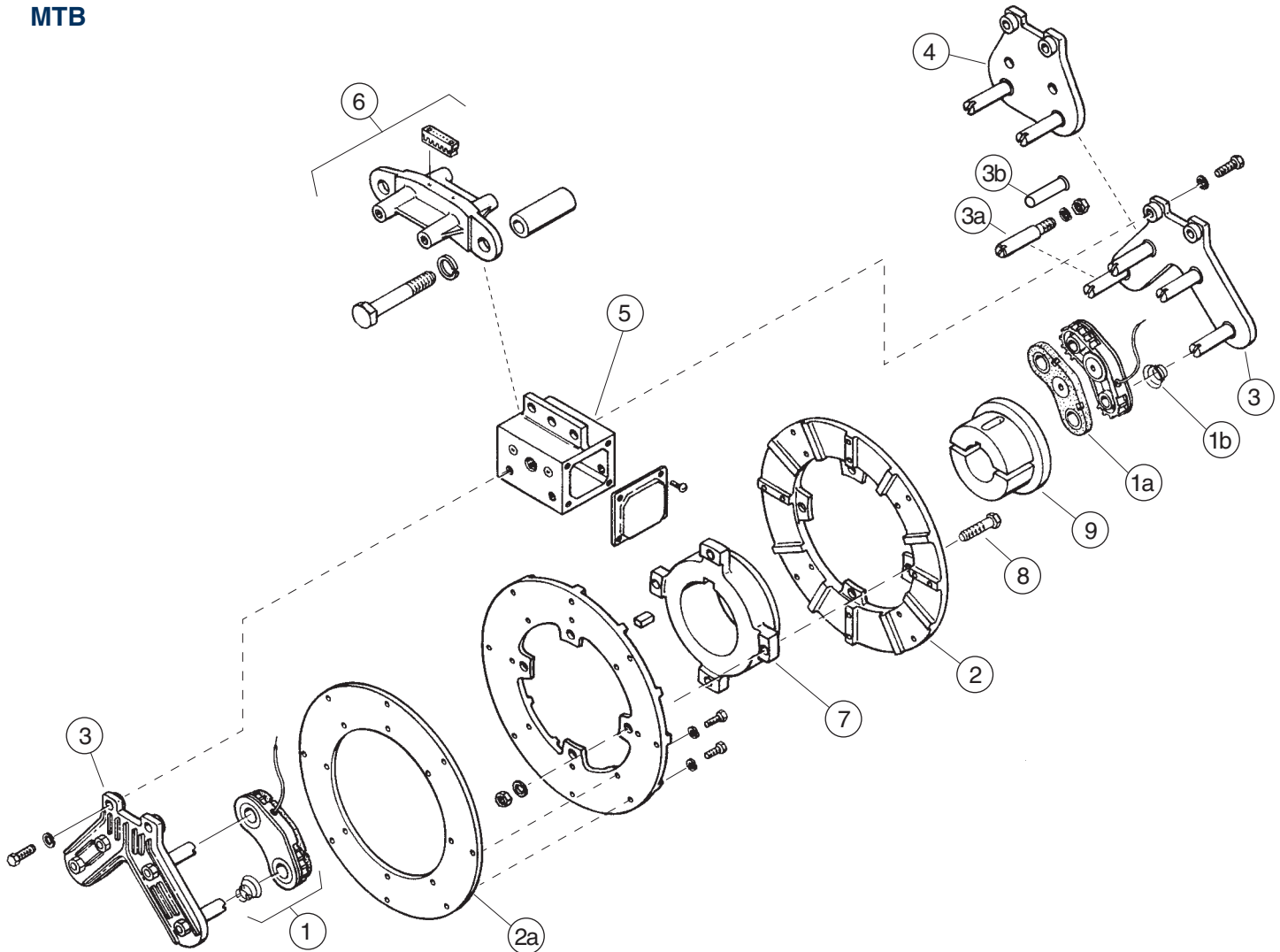

Part Numbers

Item	Description	10" Armature	15" Armature	20" Armature
1	Magnet Assembly	5216-631-004	5216-631-004	5216-631-004
1a	Friction Pad (Replacement Part Only)	5216-101-003	5216-101-003	5216-101-003
1b	Preload Spring	808-0008	808-0008	808-0008
2	Armature (Replaceable Face & Carrier)	5216-111-001	5216-111-003	5216-111-004
2a	Steel Replacement Face	5216-101-012	5216-101-011	5216-101-013
3	Dual Magnet Carrier Assembly	5216-295-002	5216-295-001	5216-295-001
3a	Male Pin Only (Includes Nut & Lockwasher)	5216-101-010	5216-101-010	5216-101-010
3b	Female Pin Kit	5216-101-008	5216-101-008	5216-101-008
4	Single Magnet Carrier Assembly	5216-295-003	5216-295-003	5216-295-003
5	Series 10-0, 15-0, & 20-0 Universal Mounting Bracket (2)	5216-101-020	5216-101-020	5216-101-020
	Series 10-10, 15-15, & 20-20 Universal Mounting Bracket (2)	5216-101-021	5216-101-021	5216-101-021
6	Bulk Head Mounting Bracket (3)	5216-101-022	5216-101-022	5216-101-022
7	Hub	540-0842	540-1382	540-1399
8	Series 10-0, 15-0, & 20-0 Armature Mounting Accessory	5216-101-004	5216-101-004	5216-101-018
	Series 10-10, 15-15, & 20-20 Armature Mounting Accessory	5216-101-005	5216-101-005	5216-101-019
9	Bushing (Customer Supplies)	Browning Type P-1	Browning Type R-1	Browning Type U-0

(1) Two of each required for each brake magnet.

(2) Includes magnet carrier (3 & 4) mounting hardware.

(3) Includes magnet mounting hardware, bracket mounting bolts and spacers.

Browning is a registered trademark of Emerson Electric Co.